

Oil - kerosene burner

One stage operation

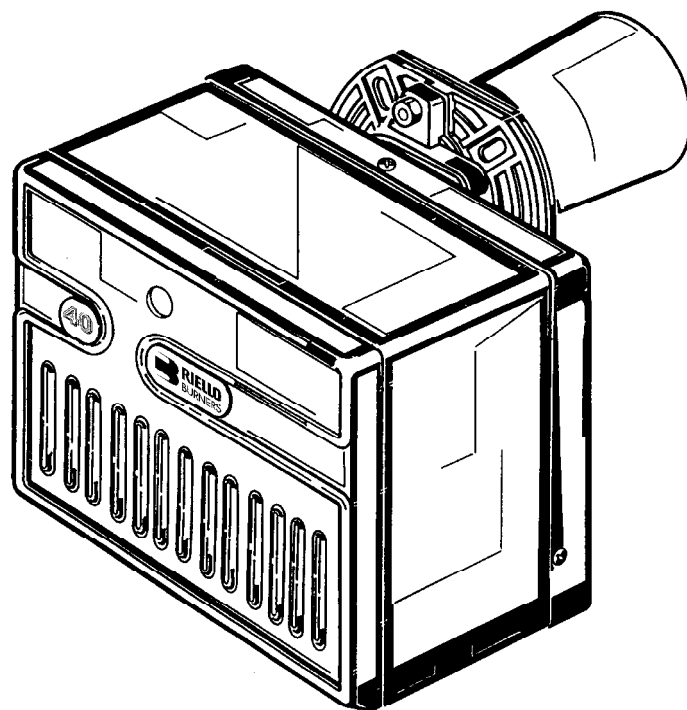

RIELLO 40

CODE	MODEL	TYPE
3743751	G3B	437T50
3743753	G3B	437T50

TECHNICAL FEATURES

Thermal power – output	19 – 35 kW – 1.6 – 3 kg/h
Fuel	Gas oil 35 sec max. viscosity 6 mm ² /s at 20 °C Kerosene 28 sec
Electrical supply	Single phase, 230V ± 10% ~ 50Hz
Motor	Run current 0.85 A – 2850 rpm – 298 rad/s
Capacitor	4 μF
Ignition transformer	Secondary 8 kV – 16 mA
Pump	Maximum pressure 14 bar (203 psi)
Absorbed electrical power	0.115 kW

- Burner with CE marking in conformity with EEC directives: EMC89/336/EEC, Low Voltage 73/23/EEC, Machines 89/392/EEC and Efficiency 92/42/EEC.
- The burner meets protection level of IP 40, EN 60529.

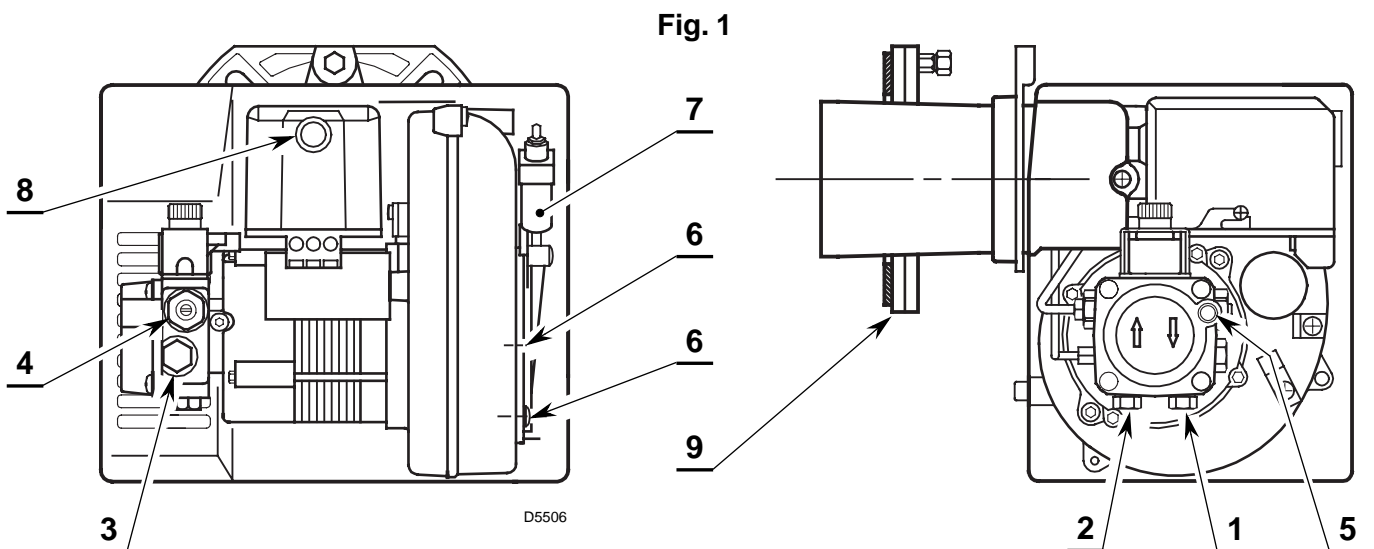

- 1 – Return line
- 2 – Suction line
- 3 – Gauge connection
- 4 – Pump pressure regulator
- 5 – Vacuum gauge connection
- 6 – Screws fixing air-damper
- 7 – Hydraulic jack with air-damper
- 8 – Lock-out lamp and reset button
- 9 – Flange with insulating gasket

EQUIPMENT

Quantity	Description
1	Flexible pipe with nipple
1	Flange with insulating gasket
2	Screws and nuts for flange
1	Screw of pump by-pass
1	Cable gland
1	Screw with two nuts for flange

WORKING RANGE (as EN 267)



DIMENSIONS

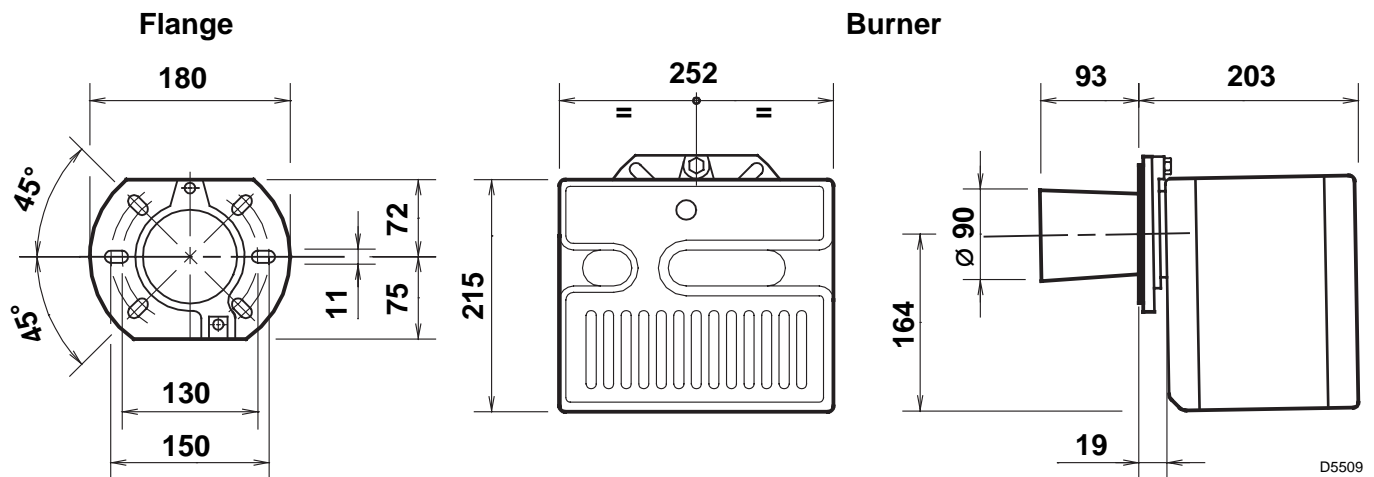

MOUNTING THE BURNER

It is necessary that the insulating gasket (9, fig. 1) is placed between the boiler door and the burner flange.

This insulating gasket has **six holes**, which, if necessary, can be modified as shown on the drawing on the right.

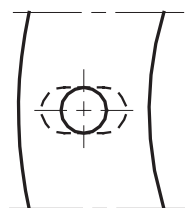

D5242

Verify that the installed burner is lightly leaned towards the button.
(See figure 2).

The burner is designed to allow entry of the flexible oil-lines on either side of the burner.

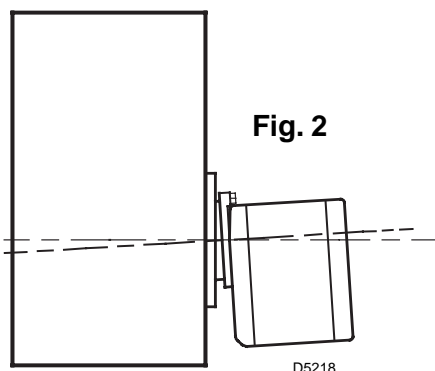

BURNER FIXING

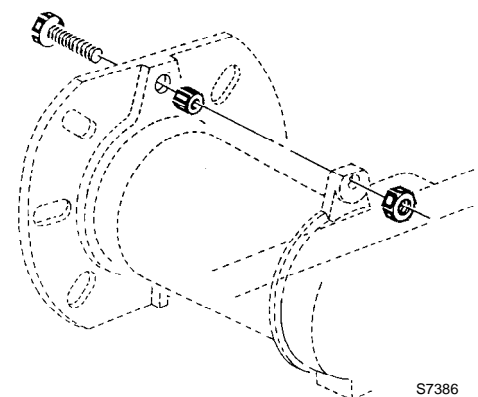

OIL LINES

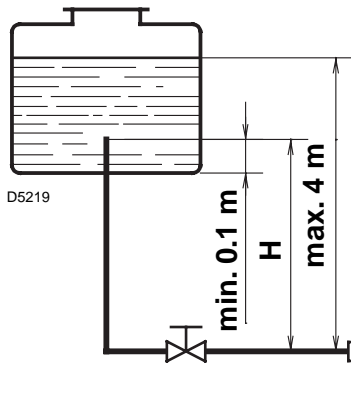

PRIMING THE PUMP

Loosen the plug of the vacuum gauge (5, fig. 1) and wait until the fuel flows out.

H meters	L meters	
	I. D. 8 mm	I.D. 10 mm
0.5	10	20
1	20	40
1.5	40	80
2	60	100

H = Difference of level.

L = Max. length of the suction line.

I.D. = Internal diameter of the oil pipes.

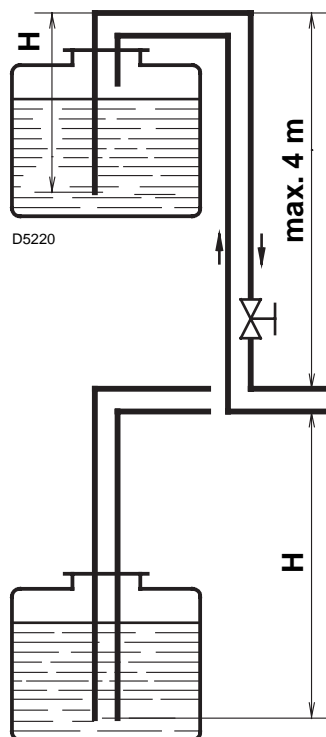

H meters	L meters	
	I. D. 8 mm	I.D. 10 mm
0	35	100
0.5	30	100
1	25	100
1.5	20	90
2	15	70
3	8	30
3.5	6	20

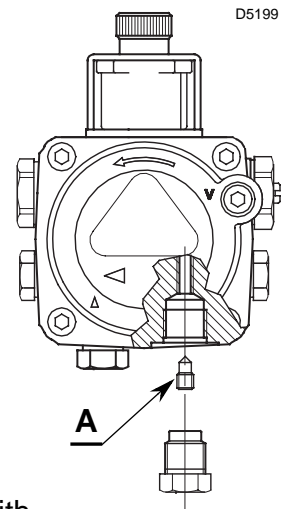

WARNING

The pump is supplied for use with a one pipe system. For use on a two pipe system, it is necessary to screw the **by-pass screw (A)** supplied as burner's accessory. (See figure).

The pump vacuum should not exceed a maximum of 0.4 bar (30 cm Hg). Beyond this limit gas is released from the oil.

Oil lines must be completely airtight.

The return line should terminate in the oil tank at the same level as the suction line; in this case a non-return valve is not required.

Should however the return line arrives over the fuel level, the non-return valve is indispensable.

This solution however is less safe than previous one, due to the possibility of leakage of the valve.

PRIMING THE PUMP:

Start the burner and wait for the priming. Should lock-out occur prior to the arrival of the fuel, await at least 20 seconds before repeating the operation.

Warning: before starting the burner make sure that the return pipe-line is not clogged: any obstruction would cause the pump seals to break.

WARNING:

- Check periodically the flexible pipes conditions. Using kerosene, they have to be replaced at least **every 2 years**.
- A metal bowl filter with replaceable micronic filter must be fitted in the oil supply pipe.

BURNER ELECTRICAL WIRING

230V ~ 50Hz

WARNING
Do not exchange the neutral with the phase.

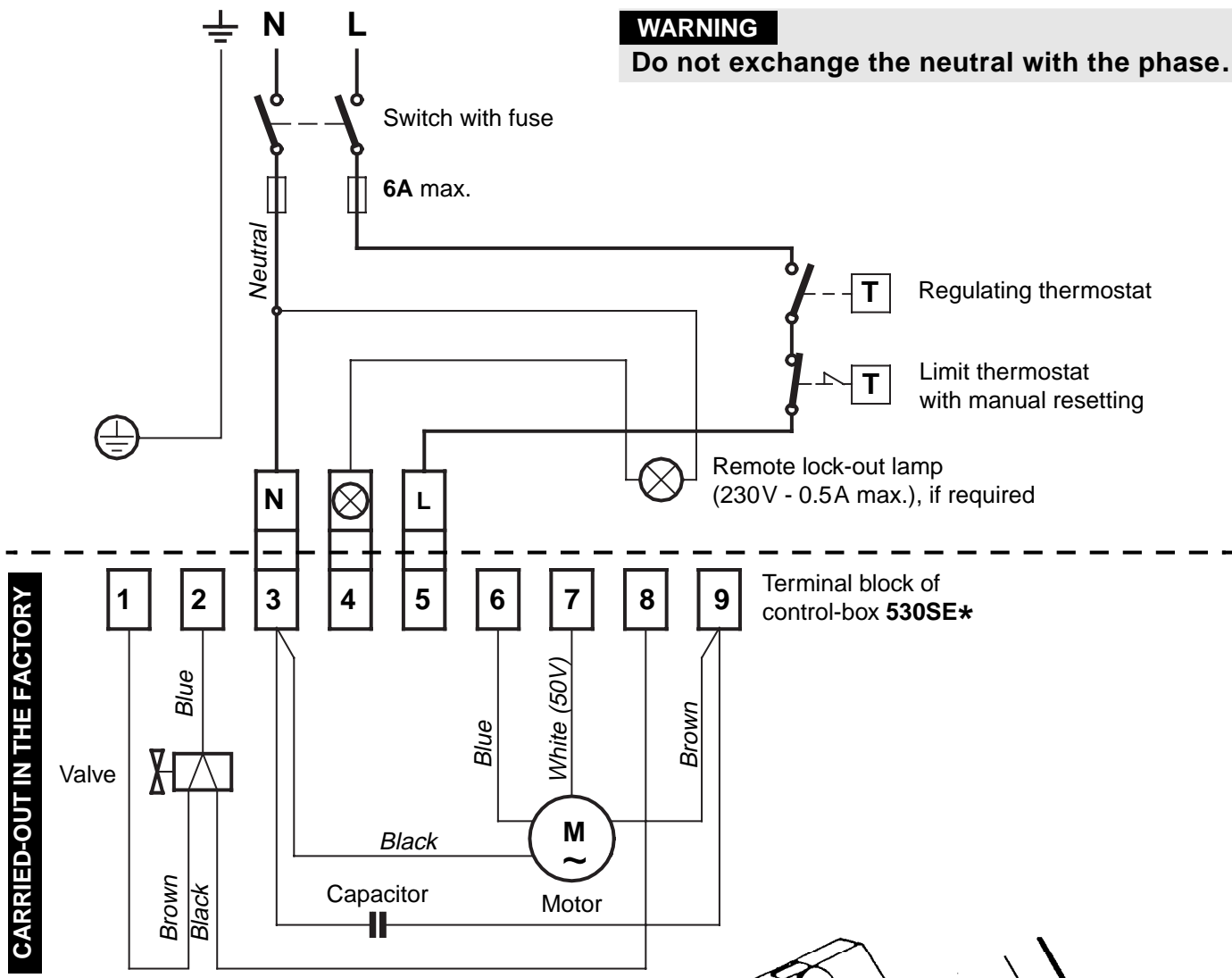

CARRIED-OUT IN THE FACTORY

D5228

NOTES

- Wires of 1 mm² section.
- The electrical wiring carried out by the installer must be in compliance with the rules in force in the Country.
- **To remove the control-box from the burner, loosen screw (A) (see figure) and pull towards the arrow.**
- The photoresistance is fitted directly into the control-box (underneath the ignition-transformer) on a plug-in support.

TESTING

Check the shut-down of the burner by opening the thermostats.

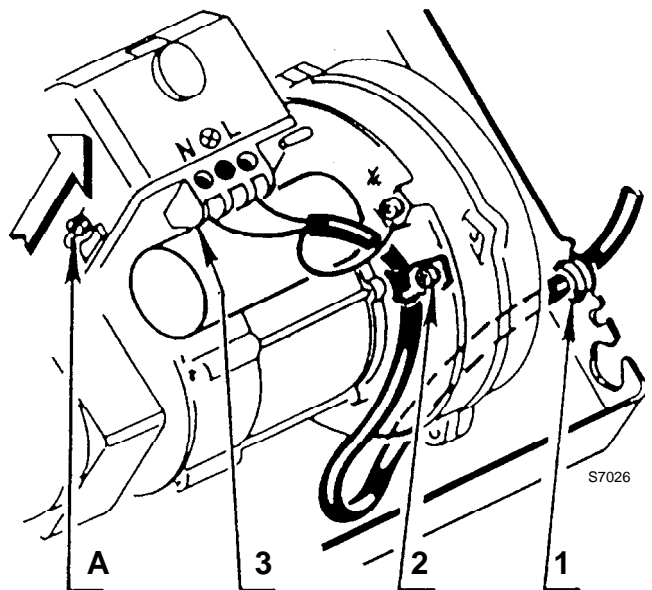

RUN OF THE ELECTRICAL CABLE

- | | |
|--------------------|------------------|
| 1 - Cable gland | N - Neutral |
| 2 - Cable-clamp | L - Phase |
| 3 - Terminal block | ⊕ - Burner-earth |

COMBUSTION ADJUSTMENT

In conformity with Efficiency Directive 92/42/EEC the application of the burner on the boiler, adjustment and testing must be carried out observing the instruction manual of the boiler, including verification of the CO and CO₂ concentration in the flue gases, their temperatures and the average temperature of the water in the boiler.

To suit the required appliance output, fit the nozzle then adjust the pump pressure and the air damper opening in accordance with the following schedule.

FUEL GAS OIL

Nozzle 1		Pump pressure 2	Burner output	Air damper adjustment 3
GPH	Angle	bar	kg/h ± 4%	Set-point
0.40	80°/60°	12	1.72	2.1
0.50	60°	12	2.15	2.3
0.60	60°	12	2.58	3.2
0.65	60°	12	2.79	3.8
0.65	60°	13	2.91	5.0

1 NOZZLES RECOMMENDED:

Monarch type R - NS
 Delavan type W - A - E
 Steinen type H - Q
 Danfoss type H - B

Angle: 60° - in most cases.
 80° - in cases of flame detachment, during ignitions at low temperatures.

2 PRESSURE:

8 bar: the pump leaves the factory set at this value, which is suitable only for kerosene.

FOR GAS OIL INCREASE PRESSURE

12 bar: pressure suitable for gas oil in most cases.
14 bar: improves flame retention; it is therefore suitable for ignitions at low temperatures.

FUEL KEROSENE

Nozzle 1		Pump pressure 2	Burner output	Air damper adjustment 3
GPH	Angle	bar	kg/h ± 4%	Set-point
0.50	60°	8	1.5	1.8
0.60	60°	8	1.8	2.1
0.65	60°	8	1.9	2.4
0.75	60°	8	2.2	2.6
0.85	60°	8	2.5	3.3
1.00	60°	8	3.0	4.5

1 NOZZLES RECOMMENDED:

Monarch type R - NS
 Delavan type W - A - E
 Steinen type H - Q
 Danfoss type H - B

2 PRESSURE:

8 bar: the pump leaves the factory set at this value.

10 bar: maximum pressure for kerosene.

3 AIR DAMPER ADJUSTMENT: The mobile air damper (1) operated by the jack (2) assures the complete opening of the air intake.

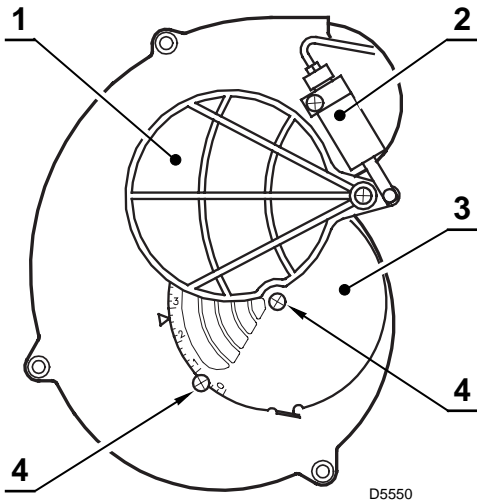

The regulation of the air-rate is made by adjusting the fixed air damper (3), after loosening the screws (4). When the optimal regulation is reached, **screw tight the screws (4)** to assure a free movement of the mobile air damper (1).

The settings indicated in the schedule refer to the burner with its metal cover fitted and the combustion chamber with “zero” depression.

These regulations are purely indicative.

Each installation however, has its own unpredictable working conditions: actual nozzle output; positive or negative pressure in the combustion-chamber, the need of excess air, etc. All these conditions may require a different air damper setting.

It is important to take account of the fact that the air output of the fan differs according to whether the burner has its metal cover fitted or not.

Therefore we recommended to proceed as follows:

- adjust the air damper as indicated in the schedule (3);
- mount the cover, simply by means of the upper screw;
- check smoke number;
- should it become necessary to modify the air output, remove the cover by loosening the screw, adjust the air damper, remount the cover and finally recheck the smoke number.

ELECTRODE SETTING

Attention:

Before assembling or removing the nozzle, loosen the screw (A) and move the electrodes ahead

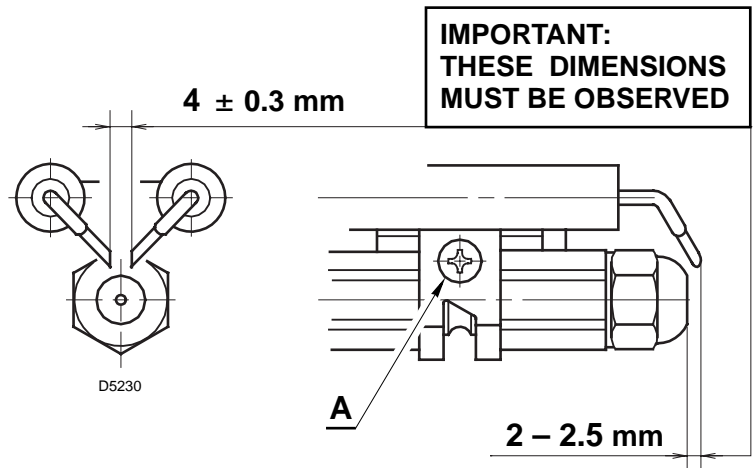

BURNER START-UP CYCLE

